

BRY100 / ABR100 User Manual

Version 1.01



Contents

BRY100 / ABR100 General Description	3
BRY100 / ABR100 Technical Specifications	3
BRY100 / ABR100 Advertising Package Definition	4
BRY100 / ABR100 Connection Service Definition	5
AES128 Encryption Authorization	5
Encryption Authorization Process	6
Exception Synchronization	6
Authorization Overtime Disconnect	7
BRY100 / ABR100 Command Format	7
Error Code	8
Set Command	8
Disable Relay	8
The AT@SET=5 command is used to disable relay	8
Enable Relay	8
Gradual Enable Relay	9
Gradual Disable Relay	10
Enable Output Duration	10
5.4.6 Encryption Authorization	11
Get Command	11
Get Version Information	11
Get Relay State	12
BRY100 / ABR100 Firmware Upgrade	13

BRY100 / ABR100 General Description

BRY100 / ABR100 is professional BLE 5.1 relay. BRY100 is not encrypted relay. ABR100 is Encrypted relay.

BRY100 / ABR100 Technical Specifications

Parameter	Specification
BLE Module	GR5513
BLE Version	BLE 5.1
Operating Voltage	7 – 32 V
Operating Temperature	-40°C ~ +85°C
Transmission Distance	Up to 150 m
Transmission Interval	100 ms
ABR100 Encryption	AES 128
Maximum Load Current	6A@250VAC / 6A@30VDC
The Max Switch Voltage	400VAC/125VDC
The Max Switch Current	6A
The Max Switch Power	1500VA/180W

BRY100 / ABR100 Pins Description

Pin No	Pin Names	Color	Description
1	VDD	RED	Power 8 – 32 V
2	GND	BLACK	Ground
3	RELAY_COM	WHITE	Common
4	RELAY_NO	YELLOW	Normal opened
5	RELAY_NC	GREEN	Normal closed

BRY100 / ABR100 Pins Description

Connected to BLE relay (ABR100) by Bluetooth. After Connected, the master device is required to perform the **Encryption Authorization** process with the BLE relay (ABR100). The authorization timeout period is 10 seconds, if the master device has not completed the process in 10 seconds, the BLE relay (ABR100) will actively disconnect.

After the authorization is successful, you can control relay output, refer to the following:

The **AT@SET=5#** command is used to disable relay, relay NC pin switch to relay COM pin.

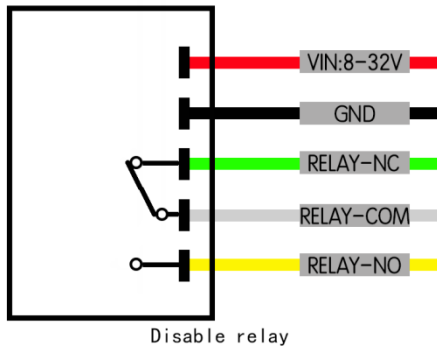

The **AT@SET=6#** command is used to enable relay, relay NO pin switch to relay COM pin.

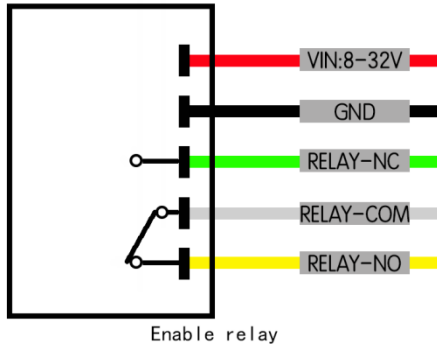

Notice: After the device is powered on, the relay's state depends on its state at the last power-off. After the device is powered off, the state of relay is always disabling state.

BRY100 / ABR100 Advertising Package Definition

Offset	Length	Frame Type	Value	Details
0	1	Length	0x02	
1	1	Type	0x01	
2	1	Data	0x06	
3	1	Length	0x0A	
4	1	Type	0x16	
5	2	Serve Type	0xEBFF	(Little Endian) 0xFFEB
7	1	Device Type	0xF0	BLE relay's device type is 0xF0
8	1	Frame	01	
9	3	Version	0x010203	(Big Endian) version format: R01A02V03
12	1	Encrypt state	0x01	
13	1	Relay Output State	0x01	
14	1	Length	0x0B	
15	1	Type	0x09	
16	6	Product Name	"ABR100"	(Big Endian) "ABR100"

- ✧ <Device Type>: 0xF0 value expresses ABR100.
- ✧ <Frame>: 0x01 value expresses "AT DEV" Advertisement.
- ✧ <Version>: The format of software version is R01A02V03.
- ✧ <Encrypt>: Whether the device's communication is encrypted. ABR100 defaults used AES128 to

encrypted communication.

- ✧ <Relay Output State>: It expresses relay output state, refer to the following:
 - 0: Relay NC.
 - 1: Relay NO
 - 2: Gradual NC Process
 - 3: Gradual NO Process
 - 4: Enable Output Duration

BRY100 / ABR100 Connection Service Definition

Service Definition	
Control Service	
Service UUID	00002e00-0000-1000-8000-00805f9b34fb
Characteristic1	
Read UUID	00002e21-0000-1000-8000-00805f9b34fb
Max Length	180 Byte
Characteristic2	
Write UUID	00002e22-0000-1000-8000-00805f9b34fb
Max Length	180 Byte

BRY100 / ABR100 Communication commands

Before communication commands, need first authorization. When master unit connected to BLE relay, if have not do authorization success in 10 seconds, BLE relay will active disconnect BLE connection. After authorization success, master unit can communication with BLE relay. Data exchange process is using AES-128 encrypt.

AES128 Encryption Authorization

The ABR100 secures communication by combining AES-128 encryption with an identity Authorization process. In this process, other device is the master and ABR100 is the slave. All control commands are dynamically encrypted using AES. Refer to the document *Assistant Telematics BLE AES Encryption Protocol* for AES details.

Encryption Authorization Process

Encryption Authorization Process

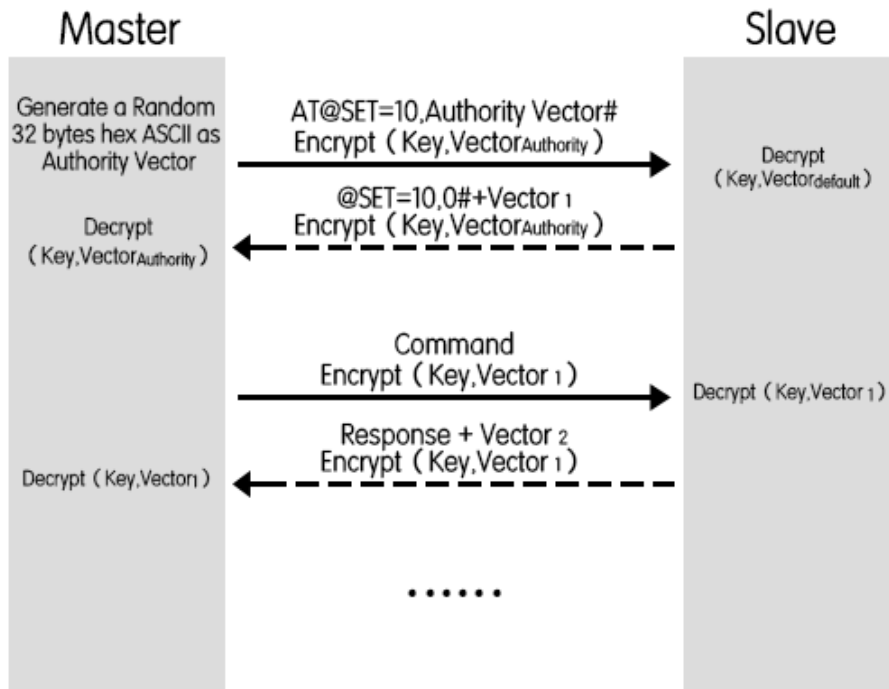

Step 1: Master request

The master sends “AT@SET=10, Authority Vector#” command that encrypted command by AES-128. The “Authority Vector” is a 32 bytes hex ASCII data generated randomly by master. For example, if the master generates an authority vector:

{0x00,0x11,0x22,0x33, 0x44,0x55,0x66,0x77,0x88, 0x99,0xAA,0xBB,0xCC,0xDD,0xEE,0xFF},

then it needs to send “AT@SET=10,00112233445566778899AABBCCDDEEFF#”

Step 2: BLE relay verification and response

When slave received the command from master, it decrypts by initial defined key and vector to get the “Authority Vector” as reply’s encrypting vector. It then encrypts the reply “@SET:10,0# + New Vector”, and sends it back to the master. Additionally, the slave appends a 16-byte random number directly after the plaintext in each response. This random number serves as the vector for future communication, it is encrypted together with the plaintext.

Step 3: Master Verification and Subsequent Command Control

The master decrypts the response using the Authority Vector. If the format is correct, the master determines that authorization is successful. It then extracts the New Vector generated by the slave as its own new vector for subsequent control commands.

Exception Synchronization

If vector mismatch occurs between the master and slave due to any exceptions, the master can resend the AT@SET=10 command encrypted by initial defined key and vector to re-trigger the authorization process and re-synchronize the vector.

The slave can respond to the authorization command at any time.

Authorization Overtime Disconnect

The device has a connection security timeout function. After connection, the master device must initiate the Encryption Authorization Process. If the process is not completed within 10 seconds, the slave will disconnect to ensure security.

BRY100 / ABR100 Command Format

All the commands use ASCII characters. Each command has the following format:

Command Format	Command Type
AT@SET=<param1>,<param 2>,...<param N>#	Set Parameters Command
@SET:<param 1>,<param 2>,...<param N>#	Set Parameters Command Response
AT@GET=<param 1>,<param 2>,...<param N>#	Get Parameters Command
@GET:<param 1>,<param 2>,...<param N>#	Get Parameters Command Response

The “<param 1>, <param2>, ...<param N>” carries the command’s parameters. The ASCII character ‘;’ is used to separate the parameter characters. The parameter string consist of the ASCII characters: ‘0’-‘9’, ‘A’-‘Z’, ‘a’-‘z’. The ending of command with character ‘#’.

Please refer to the following flow chart figure:

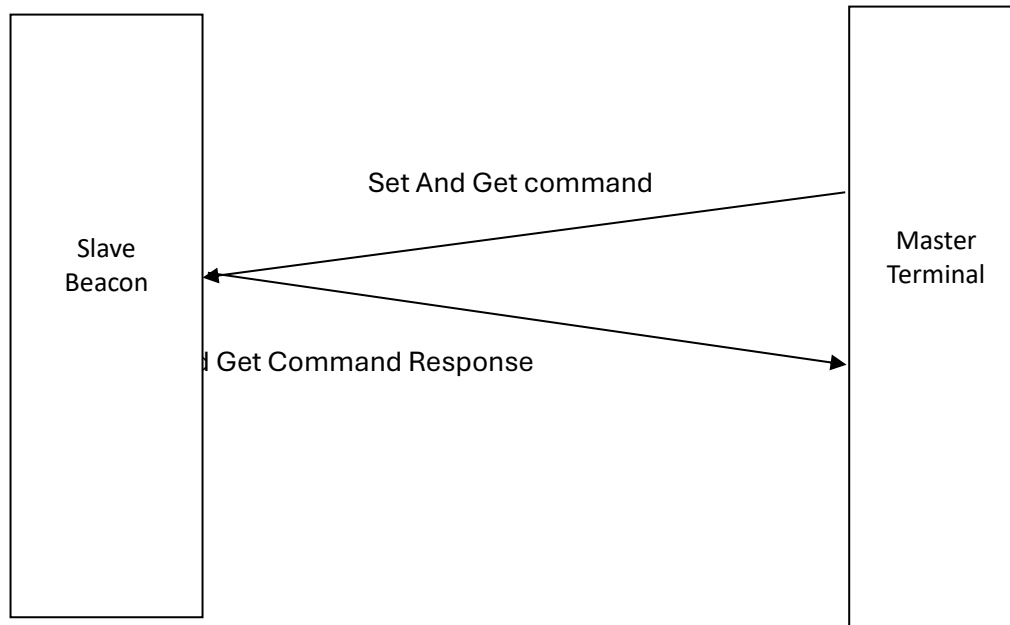

Error Code

The error code indicates the result of command execution.

Error Code	Description
0	Command Executed Successful
1	Operation Not Allowed
2	Invalid parameter

Set Command

Disable Relay

The **AT@SET=5** command is used to disable relay.

Example: AT@SET=5#				
SN	Parameter	Length (Byte)	Range/Format	Default
1	Command ID	1	'5'	'5'
2	Tail Character	1	#	#

The response of **AT@SET=5** command:

Example: @SET:5,0#				
SN	Parameter	Length (Byte)	Range/Format	Default
1	Command ID	1	'5'	'5'
2	Result	1	Please refer to the below "Error Code"	
3	Tail Character	1	#	#

Enable Relay

The **AT@SET=6** command is used to enable relay.

Example: AT@SET=6#				
SN	Parameter	Length (Byte)	Range/Format	Default
1	Command ID	1	'6'	'6'
2	Tail Character	1	#	#

The response of **AT@SET=6** command:

Example: @SET:6,0#				
SN	Parameter	Length (Byte)	Range/Format	Default
1	Command ID	1	'6'	'6'
2	Result	1	Please refer to the below "Error Code"	
3	Tail Character	1	#	#

Gradual Enable Relay

The AT@SET=7 command is used to gradual enable relay.

Example: AT@SET=7,1,10,1#				
SN	Parameter	Length (Byte)	Range/Format	Default
1	Command ID	1	'7'	'7'
2	Enable Time of first phase	<=3	1 - 100 (*100ms)	
3	One Cycle Time	<=3	1 - 100 (*100ms)	
4	Incremental Step Time	<=3	0 - 100 (*100ms)	
5	Tail Character	1	#	#

Gradual Progressive Wave Shape

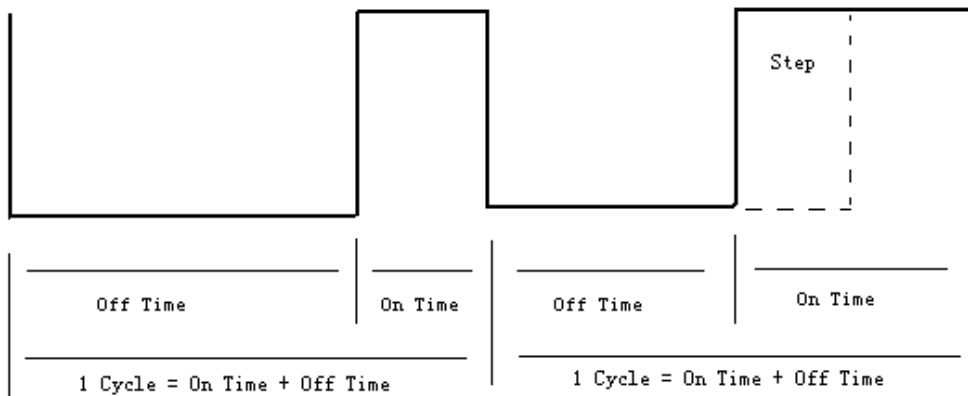

The response of AT@SET=7 command:

Example: @SET:7,0#				
SN	Parameter	Length (Byte)	Range/Format	Default
1	Command ID	1	'7'	'7'
2	Result	1	Please refer to the below "Error Code"	
3	Tail Character	1	#	#

Gradual Disable Relay

The **AT@SET=8** command is used to gradual disable relay.

Example: AT@SET=8,1,10,1#				
SN	Parameter	Length (Byte)	Range/Format	Default
1	Command ID	1	'8'	'8'
2	Enable Time of first phase	<=3	1 -100 (*100ms)	
3	One Cycle Time	<=3	1 - 100 (*100ms)	
4	Incremental Step Time	<=3	0 - 100 (*100ms)	
5	Tail Character	1	#	#

Gradual Progressive Wave Shape

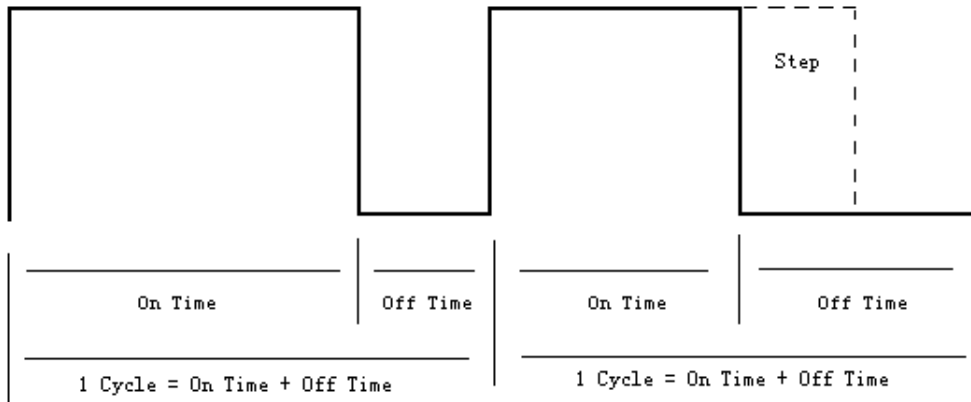

The response of **AT@SET=8** command:

Example: @SET:8,0#				
SN	Parameter	Length (Byte)	Range/Format	Default
1	Command ID	1	'8'	'8'
2	Result	1	Please refer to the below "Error Code"	
3	Tail Character	1	#	#

Enable Output Duration

The **AT@SET=9** command is used to Enable Output Duration.

Example: AT@SET=9,1,10,1#				
SN	Parameter	Length (Byte)	Range/Format	Default
1	Command ID	1	'9'	'9s'

2	Enable State	1	0 1	1
3	Active Duration	<=4	1 – 3600 (sec)	30
4	Inactive Duration	<=4	1 – 3600 (sec)	30
5	Toggle Times	<=3	0 - 256	
6	Tail Character	1	#	#

The response of **AT@SET=9** command:

Example: @SET:9,0#				
SN	Parameter	Length (Byte)	Range/Format	Default
1	Command ID	1	'9'	'9'
2	Result	1	Please refer to the below "Error Code"	
3	Tail Character	1	#	#

Encryption Authorization

The **AT@SET=10** command is used to authorize the master's identity.

Example: AT@SET=10,00112233445566778899AABBCCDDEEFF#				
SN	Parameter	Length (Byte)	Range/Format	Default
1	Command ID	1	"10"	"10"
2	Authority Vector	32	'0' – '9' 'A' – 'Z' 'a' – 'f'	
3	Tail Character	1	#	#

The response of **AT@SET=10** command:

Example: @SET:10,0#				
SN	Parameter	Length (Byte)	Range/Format	Default
1	Command ID	1	"10"	"10"
2	Result	1	Please refer to the below "Error Code"	
3	Tail Character	1	#	#

Get Command

Get Version Information

The **AT@GET=2** command is used to get version information.

Example: AT@GET=2#				
SN	Parameter	Length (Byte)	Range/Format	Default

1	Command ID	1	'2'	'2'
2	Tail Character	1	#	#

✧ <Command ID>: This is ID number of command and the ID number is unique.

The response of **AT@GET=2** command:

Example: @GET:2,0,000101#				
SN	Parameter	Length (Byte)	Range/Format	Default
1	Command ID	1	'2'	'2'
2	Result	1	Please refer to the below "Error Code"	
3	Software Version	<=6		
4	Tail Character	1	#	#

Get Relay State

The **AT@GET=3** command is used to get current relay state.

Example: AT@GET=3#				
SN	Parameter	Length (Byte)	Range/Format	Default
1	Command ID	1	'3'	'3'
2	Tail Character	1	#	#

✧ <Command ID>: This is ID number of command and the ID number is unique.

The response of **AT@GET=3** command:

Example: @GET:3,0,0#				
SN	Parameter	Length (Byte)	Range/Format	Default
1	Command ID	1	'3'	'3'
2	Result	1	Please refer to the below "Error Code"	
3	Relay state	1	'0' – '4'	
4	Tail Character	1	#	#

✧ <Relay state>: It expresses current relay state.

- 0: Relay NC.
- 1: Relay NO
- 2: Gradual NC Process
- 3: Gradual NO Process

4: Enable Output Duration

BRY100 / ABR100 Firmware Upgrade

Preparation

- BRY100/ABR100: Ensure the device can broadcast and be discovered by the phone; it is better to know the device's Bluetooth address.
- Software: Install the GRToolbox App.

https://www.goodix.com/en/software_tool/grtoolbox

- Firmware: Contact support@iot-at.com to get the latest firmware *.bin file, save it into your mobile phone.

Upgrade Procedure

- 1.1 Open the App and enable Bluetooth permissions on your phone.
- 1.2 Find the target device to be upgraded by its Bluetooth address or device name, and click "Connect".
- 1.3 Filter a successful connection, click the rocket icon to enter the upgrade interface.

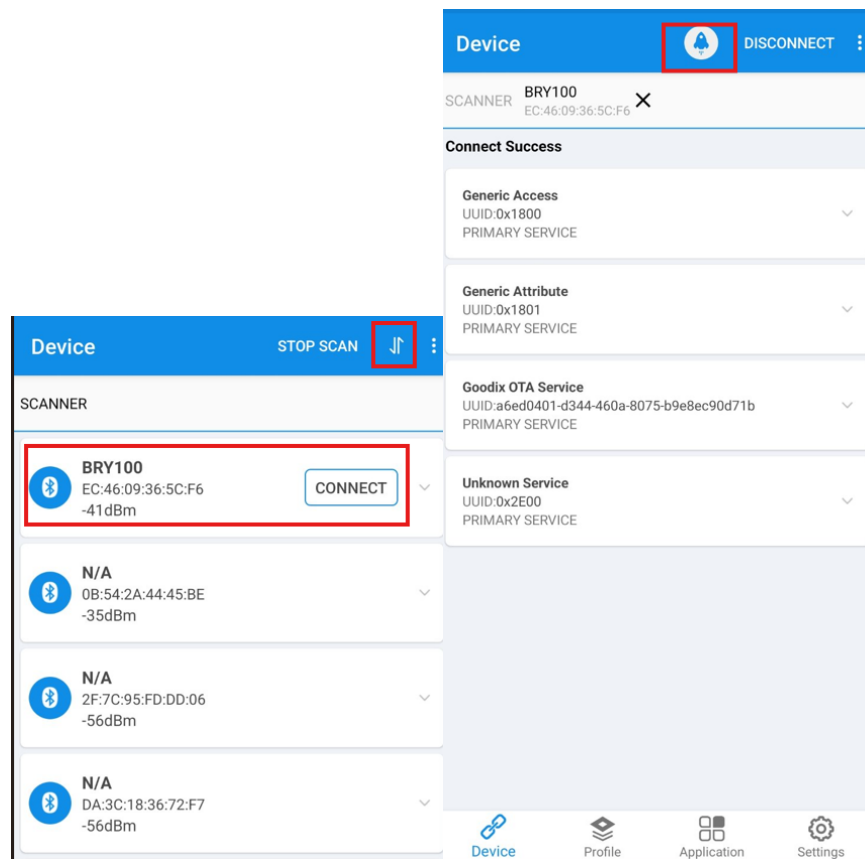

1.4 Choose the **Copy Mode**, enter **Copy Address – 01040000**, and then select fw file *.BIN and press Update.

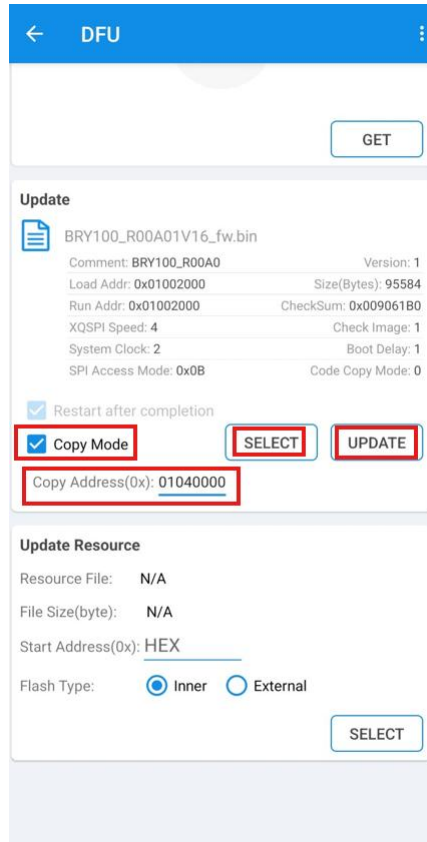

1.5 Firmware Update success.

